

Accessories for Micrometers



41 H

Stand 41 H

- For mounting a micrometer
- Enables the user to use both hands to operate the micrometer and / or to insert a work piece
- Sturdy, heavy-duty base, hammer-dimple enamel finish
- Clamping jaws are rubber lined to protect micrometer, the clamping jaws can be tilted
- Both the clamping jaws and hinge are fixed in place with one screw

Dimensions
(D x W x H)

130 x 100 x 90 mm

Order no.

4158000

Ball shaped Anvil Attachment 40 k

- For measuring the thickness, for example: of pipe walls
- Slips over every anvil or the spindle with a dia. 7.5 mm
- Carbide ball, Ball dia. 5 ± 0.002 mm

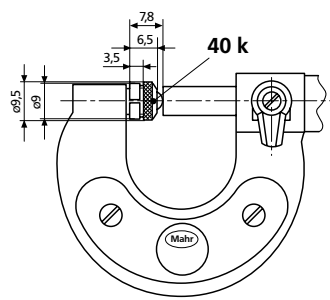

40 k

Order no. 4130099

Setting Standards 43 A

- For testing the basic setting of a micrometer
- Heat insulated handle
- Manufacturing tolerance js 2



Length
mm

Order no.

Length
inch

Order no.

25	4159400	1"	4159940
50	4159401	2"	4159941
75	4159402	3"	4159942
100	4159403	4"	4159943
125	4159404	5"	4159944
150	4159405	6"	4159945
175	4159406	7"	4159946

Thread Pin Gage 426 M in holder

- For determining the pitch diameter of external threads according to the three wire method
- Slips over every anvil or the spindle
- Pin gages are hardened and lapped



426 M

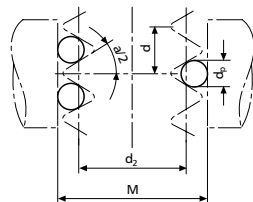

Pin gage dia.	Manufacturing tol.	Mounting hole
0.17 - 5.05 mm	$\pm 0.5 \mu\text{m}$	dia. 6.5 mm / 7.5 mm

Order no. and further details see page 13-18

Wooden Cases for Micrometer

For measuring ranges over 100 mm the following wooden cases are available:

	40 SH	40 SM	Order no.
Meas. range	100-125	95-120	4130064
mm	125-150	120-145	4130065
	150-175	145-170	4130066
	175-200	170-195	4130067